

## Flux Puppy – An open-source software application and portable system design for low-cost manual measurements of CO<sub>2</sub> and H<sub>2</sub>O fluxes



Mariah S. Carbone<sup>a,b,\*</sup>, Bijan Seyednasrollah<sup>a,c,d</sup>, Tim T. Rademacher<sup>a,c,d</sup>, David Basler<sup>d</sup>, James M. Le Moine<sup>a,c</sup>, Samuel Beals<sup>c</sup>, James Beasley<sup>c</sup>, Andrew Greene<sup>c</sup>, Joseph Kelroy<sup>c</sup>, Andrew D. Richardson<sup>a,c</sup>

<sup>a</sup> Center for Ecosystem Science and Society, Northern Arizona University, Flagstaff, AZ, 86011, United States

<sup>b</sup> Department of Biological Sciences, Northern Arizona University, Flagstaff, AZ, 86011, United States

<sup>c</sup> School of Informatics, Computing, and Cyber Systems, Northern Arizona University, Flagstaff, AZ, 86004, United States

<sup>d</sup> Department of Organismic and Evolutionary Biology, Harvard University, Cambridge, MA, 02138, United States

### ARTICLE INFO

#### Keywords:

Manual chamber CO<sub>2</sub> measurements

LI-820

LI-830

LI-840

LI-850

Open source

Portable system

Respiration

### ABSTRACT

Manual chamber-based measurements of CO<sub>2</sub> (and H<sub>2</sub>O) fluxes are important for understanding ecosystem carbon metabolism. Small opaque chambers can be used to measure leaf, stem and soil respiration. Larger transparent chambers can be used to measure net ecosystem exchange of CO<sub>2</sub>, and small jars often serve this purpose for laboratory incubations of soil and plant material. We developed an Android application (app), called Flux Puppy, to facilitate chamber-based flux measurements in the field and laboratory. The app is designed to run on an inexpensive handheld Android device, such as a tablet or phone, and it has a graphical user interface that communicates with a LI-COR LI-820 and LI-830 (CO<sub>2</sub>) or LI-840 and LI-850 (CO<sub>2</sub>/H<sub>2</sub>O) infrared gas analyzer. The app logs concentrations of CO<sub>2</sub> and H<sub>2</sub>O, cell temperature and pressure at 1 Hz, displays the output graphically, and calculates the linear regression slope, R-squared, and standard error of the CO<sub>2</sub> time series. A metadata screen allows users to enter operator, site, and plot information, as well as take a photograph using the Android device's built-in camera, and log measurement location using the device GPS. Additionally, there is a notes field, which can be revised after the measurements are taken. Data files (the 1 s raw data, photograph, and metadata including statistics calculated from the raw data) are then transmitted off the device through file sharing options (Gmail, Outlook, Google Drive, Dropbox etc.). Because Flux Puppy code is open-source (available on GitHub) and the flux measurement system we describe is relatively inexpensive and straightforward to assemble, it should be of broad interest to the carbon cycling community.

### 1. Introduction

Manual chamber-based measurements of CO<sub>2</sub> (and H<sub>2</sub>O) fluxes remain an important tool in ecology and Earth science. A common application of this tool is in the field, where small opaque chambers can be used to measure leaf, stem, and soil respiration (Lavigne et al., 1997) and larger transparent chambers and tents (Arnold and Obrist, 2003) can be used to measure net ecosystem exchange of CO<sub>2</sub>. Small containers, such as mason jars, often serve as chambers for incubations of soil and plant material in the laboratory. While data collection is increasingly automated, there are still numerous applications where the manual approach is desirable. Examples include intensive field and laboratory campaigns, remote locations where automation is impractical, studies where low-cost is essential, or student projects where

small samples sizes are all that is required.

A number of off-the-shelf portable manual CO<sub>2</sub> (and H<sub>2</sub>O and CH<sub>4</sub>) flux measurement systems are commercially available (e.g. LI-7815, LI-COR; EGM-5, PP systems; and UGGA, Los Gatos Research). However, these systems can be costly, and the software developed to interface with these instruments remains limited to basic data collection, not processing, and is not easily customizable. Prior to the development of these units, scientists frequently assembled their own portable systems optimized for non-steady state chamber measurements, where the flux is calculated from the rate of increase over time (slope) of CO<sub>2</sub>/H<sub>2</sub>O concentration in a chamber of known volume (Livingston and Hutchinson, 1995). LI-COR's 800-series Infrared Gas Analyzer (IRGA) has in the past been commonly used as a key component in such self-built systems. These analyzers are not fast-response, as would be

\* Corresponding author at: Center for Ecosystem Science and Society, Northern Arizona University, P.O. Box 5620, Flagstaff, AZ, 86011, United States.

E-mail address: [mariah.carbone@nau.edu](mailto:mariah.carbone@nau.edu) (M.S. Carbone).

<https://doi.org/10.1016/j.agrformet.2019.04.012>

Received 29 October 2018; Received in revised form 11 April 2019; Accepted 14 April 2019

Available online 20 April 2019

0168-1923/ © 2019 The Author(s). Published by Elsevier B.V. This is an open access article under the CC BY-NC-ND license

(<http://creativecommons.org/licenses/by-nc-nd/4.0/>).

required for eddy covariance flux measurements; however, they are robust and durable, relatively inexpensive, and have low power consumption. Additionally, they can report data at up to 2 Hz with good precision, which is sufficient for closed chamber measurements. These traits make the 800-series IRGAs ideal for a portable chamber flux measurement system. However, data visualization and collection from these instruments is, and has always been, limiting. Data can be directly streamed to a simple data logger (with or without a screen) collecting near-real time output of CO<sub>2</sub> and H<sub>2</sub>O, or data can be visualized on a computer with the provided software. The computer software interface is preferred because it enables the user to see a graph of the data, start and stop logging, as well as maintain other functions of the instrument such as calibration. However, this interface requires that a flux measurement system incorporate a laptop with a Windows operating system, which limits portability due to size, battery lifetime, connection cords, as well as overall carrying awkwardness. Moreover, the LI-COR software does not have capabilities for rapidly processing the collected data in the field for real-time quality control, or for attaching notes and other important metadata to the logged data files.

Motivated to make more user-friendly and field-efficient manual flux measurement systems, we developed an Android application (app) called Flux Puppy (inspired by the “Gas Hound” nickname of the original LI-COR LI-800) that runs on a handheld Android device (tablet or phone) and interfaces with LI-820 or LI-830 (CO<sub>2</sub> only) and LI-840 or LI-850 (CO<sub>2</sub> and H<sub>2</sub>O) IRGAs. This new app enables the user to visualize, manipulate, and log live readout of data, store various forms of metadata including a photo, calculate basic statistics from all, or a subset of the data collected, and wirelessly transfer the bundled data, metadata, and statistics to the user from within the app. The app was developed in Java to be compatible with Google’s Android devices.

Because the Flux Puppy code is open-source and freely available, it can be customized to the user’s needs. Together with enhanced functionality, we believe that this makes Flux Puppy a major improvement over currently available software. To further enable a wider scientific community to make relatively low-cost manual flux measurements, we also describe here the design, including a full list of all required components, of a portable flux measurement system for use with Flux Puppy. The cost of this system is less than \$6000 US dollars (including approximately \$5000 for the IRGA alone), which is considerably less than commercially-available systems.

## 2. Design

### 2.1. System components

Our manual CO<sub>2</sub>/H<sub>2</sub>O flux measurement system is designed to be compact, portable, and battery-operated for a full day of use in the field. The constructed system is illustrated in Fig. 1, while information on the specific model, manufacturer, cost, and associated weight of each component is listed in Table 1. The primary component of the system is the LI-COR IRGA (Lincoln, NE, USA), models LI-820 and LI-830 that measure CO<sub>2</sub> or the LI-840 and LI-850 that measure both CO<sub>2</sub> and H<sub>2</sub>O. The IRGA data output is visualized and saved on an Android device (tablet or smart phone). We have developed and tested a system using an 8 inch Lenovo Tab 4 (Haidian District, Beijing, China), which offers a battery life of 20 h, but any tablet or phone running the Android 7.0 (or more recent) operating system should be compatible. The Android device can be directly connected to the IRGA serial port with a serial-to-USB cable and a micro-to-USB adapter. This is also known as a USB on-the-go (OTG) adapter, and the Android device has to support OTG to be able to use this. Alternatively, a wireless connection is possible, illustrated in Fig. 1, with a serial-to-Bluetooth adapter (IO-GEAR GBC232A, Irvine, CA, USA; this software mode is called *Flux Puppy Unleashed*). For this, it is necessary to configure the communication settings of the Bluetooth adapter to match those of the IRGA, where the RS-232 port is configured as Data Terminal Equipment (DTE)

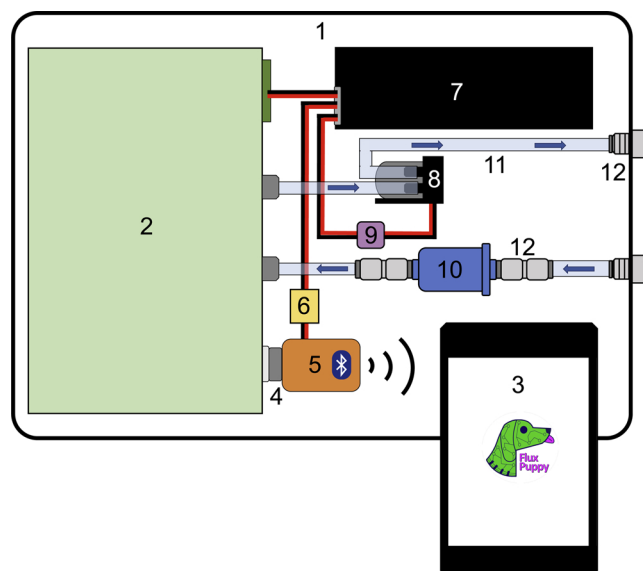

**Fig. 1.** A schematic of the portable system box called the Dog House. Numbers identify individual components and correspond to column 1 in Table 1. They are: 1) case, 2) IRGA, 3) tablet or phone, 4) null modem cable/adaptor, 5) Serial-to-Bluetooth adapter, 6) 12V-to-5V step down transformer, 7) 12V battery and housing, 8) pump, 9) switch, 10) air filter, 11) tubing, and 12) tubing connections. Drawings are close to but not exactly to scale for clarity purposes.

with no hardware handshaking and the following settings: BaudRate = 9600bps, DataBits = 8, Parity = None, StopBits = 1, and FlowControl = None (see IRGA manual). The serial-to-Bluetooth adapter must be connected to the IRGA serial port using a null modem adapter (or null modem cable, if greater flexibility in positioning the adapter is required), with cross linked connections. This null modem will normally have female connectors on both ends. A terminal app, (e.g. Bluetooth Terminal) can be used for verification that data is correctly streaming from the IRGA to the Android device, as well as for additional debugging purposes.

We fit these components in a durable 37.2 × 26 × 15.5 cm interior dimension case (Pelican 1450, Pelican, Torrance, CA, USA). We installed an air filter upstream of the IRGA air-in connection, and a small pump (Boxer12K, Boxer GmbH, Ottoburen, BY, Germany) downstream of the IRGA air-out connection, that pulls air through the IRGA at 1 LPM. This air filter and pump can then be connected to a chamber/incubation container specific to the user’s needs with tubing (Bev-A-Line IV, Thermoplastic Processes, Georgetown, DE, USA) and ¼ inch tubing connectors (John Guest, West Drayton, London, England). When using the wireless connection to the app, the case can be closed and the system is protected from outside elements of dirt and water. Closing the case also facilitates operation in cold weather, when it might be otherwise difficult to maintain the IRGA’s operating temperature. Finally, the PS-150, a 7-amp hour 12V rechargeable battery and housing with an on/off switch, (Campbell Scientific, Logan UT, USA) is used to power the IRGA, pump, and Bluetooth-to-serial adapter. A 12V-to-5V step down transformer (SMAKN, Shenzhen, GD, China) is needed to supply the correct voltage to the serial-to-Bluetooth adapter. The described system weighs less than 5.5 kg and will run for approximately 9 h. A spare battery can be placed in the case for additional hours of use (eventually being limited by the Android device’s battery life).

### 2.2. Flux Puppy software

Flux Puppy v1.0.0 is written in Java and designed in Android Studio, the official integrated development environment for Android systems. The current tested and stable release is available for download

**Table 1**

Manual CO<sub>2</sub> (and H<sub>2</sub>O) measurement system components, model numbers, manufacturing companies, their associated costs in US dollars (\*price per 50 ft/spool \*\*price per connector), and weight in kilograms. Number column identifies the component in Fig. 1.

Number	Component	Model	Company	Cost (USD)	Weight (kg)
1	Case	Pelican 1450	Pelican (Torrance, CA, USA)	\$95	2.79
2	IRGA	LI-820/830/840/850	Licor Inc. (Lincoln, NE, USA)	\$4900	1.12
3	Tablet	Tab 4 8 inch	Lenovo (Haidian District, Beijing, China)	\$150	0.33
	Micro–USB Adapter	Micro USB OTG Data Adapter	GearBest (Staten Island, NY, USA)	\$0.50	0.007
	Serial–USB Cable	ES-U-1001-r10	EasySync (Glasgow, South Lanarkshire, Scotland)	\$19.50	0.02
4	Null Modem Cable/adaptor	110480	Cables2Go (Moraine, OH, USA)	\$10	0.08
5	Serial–Bluetooth adapter	GBC232A	IOGEAR (Irvine, CA, USA)	\$55	0.05
6	12 V-to-5 V Step down transformer		SMAKN (Shenzhen, GD, China)	\$7	0.03
7	12 V Battery and Housing	PS-150	Campbell Scientific (Logan, UT, USA)	\$290	0.92
8	Pump	Boxer 12K	Boxer GmbH (Ottobreuren, BY, Germany)	\$145	0.03
9	Rocker Switch	SB84880	Dorman Products, Inc. (Colmar, PA, USA)	\$9	0.008
10	Air filter	9922-05DQ	Parker Hannifin Corp. (Lancaster, NY, USA)	\$34	0.021
11	Bev-A-Line IV Tubing	2140505	Thermoplastic Processes (Georgetown, DE, USA)	\$46*	0.02
12	Tubing connectors	PP1208E	John Guest (West Drayton, London, England)	\$4**	0.01
<b>Total</b>				<b>\$5765</b>	<b>5.436</b>

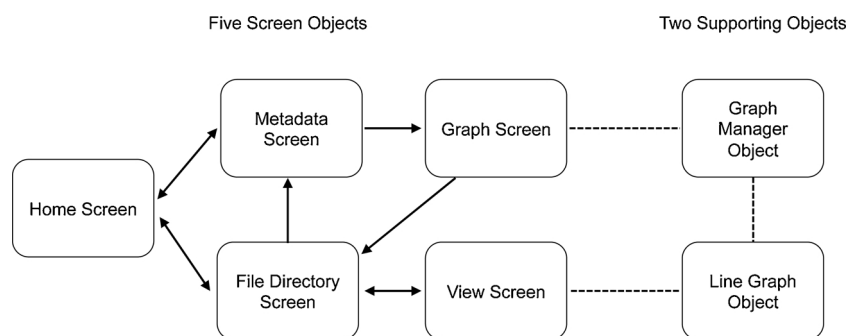

**Fig. 2.** Architecture overview of Flux Puppy. The app has five screen objects: home screen, metadata screen, graph screen, file directory screen and view screen. There are two supporting objects, the graph manager object and the line graph object.

at <http://doi.org/10.5281/zenodo.1413689> (Seyednasrollah et al., 2018). The prebuilt Android application package (APK) file can be found in the “binary” directory. The development stage source code, UML, and quick start user guide are available from the GitHub Inc. software repository at: <https://github.com/bnasr/FluxPuppy>. Thus, this app is freely available (GNU Affero General Public License, AGPL-3), documented, and can be modified to the user’s needs. An overview of the app architecture is shown in Fig. 2. There are five screen objects (home, metadata, graph, file directory, and view) and two supporting objects (graph manager and line graph).

The Home screen (Fig. 3a) is the first screen that the user sees when they open the app. It displays the app logo and version number. The Home screen consists of two navigational buttons. The “Start new data set” button will take the user to the beginning of the data collection process on the Metadata screen (Fig. 3b), while the “File Directory” button takes the user to the File Directory screen (Fig. 3d) to view already collected datasets.

The Metadata screen (Fig. 3b) initiates the data collection process for the user with various input fields listed in Table 2. This screen has eight text fields, three of which are required. All fields have character restrictions and a character limit on length. The character restrictions,

as well as other attributes for the text fields are all defined in the source code. The required fields are Operator Name, Site Name, and Sample ID. The “Start Measurement” button is disabled until the required fields are completed. The optional text fields are Temperature (°C), Comments, Longitude (degrees), Latitude (degrees), and Elevation (m). If these fields are left empty, they will be filled with “NA” when the file is saved. Because repeat measurements over the course of a day are likely made by the same operator at the same field site, Operator Name and Site Name are automatically filled in with the values of the last data entry. Time and Date are always filled in automatically from the Android device. If there is a GPS signal detected (which may not always be possible inside, or under a forest canopy, for example), Longitude, Latitude, and Elevation will be filled in automatically for the user. Without a GPS signal, location parameters can be manually entered if desired. Lastly, the user has the option to take a picture using the Android device’s built-in camera. The image is shown in the preview window of the Metadata screen and will be bundled with the saved files when data are transferred off the device. In addition, all images taken in-app by the camera are also saved in the device’s photo gallery. Once the user has entered in the required fields, the “Start Measurement” button is activated, and when pressed, this takes the user to the Graph

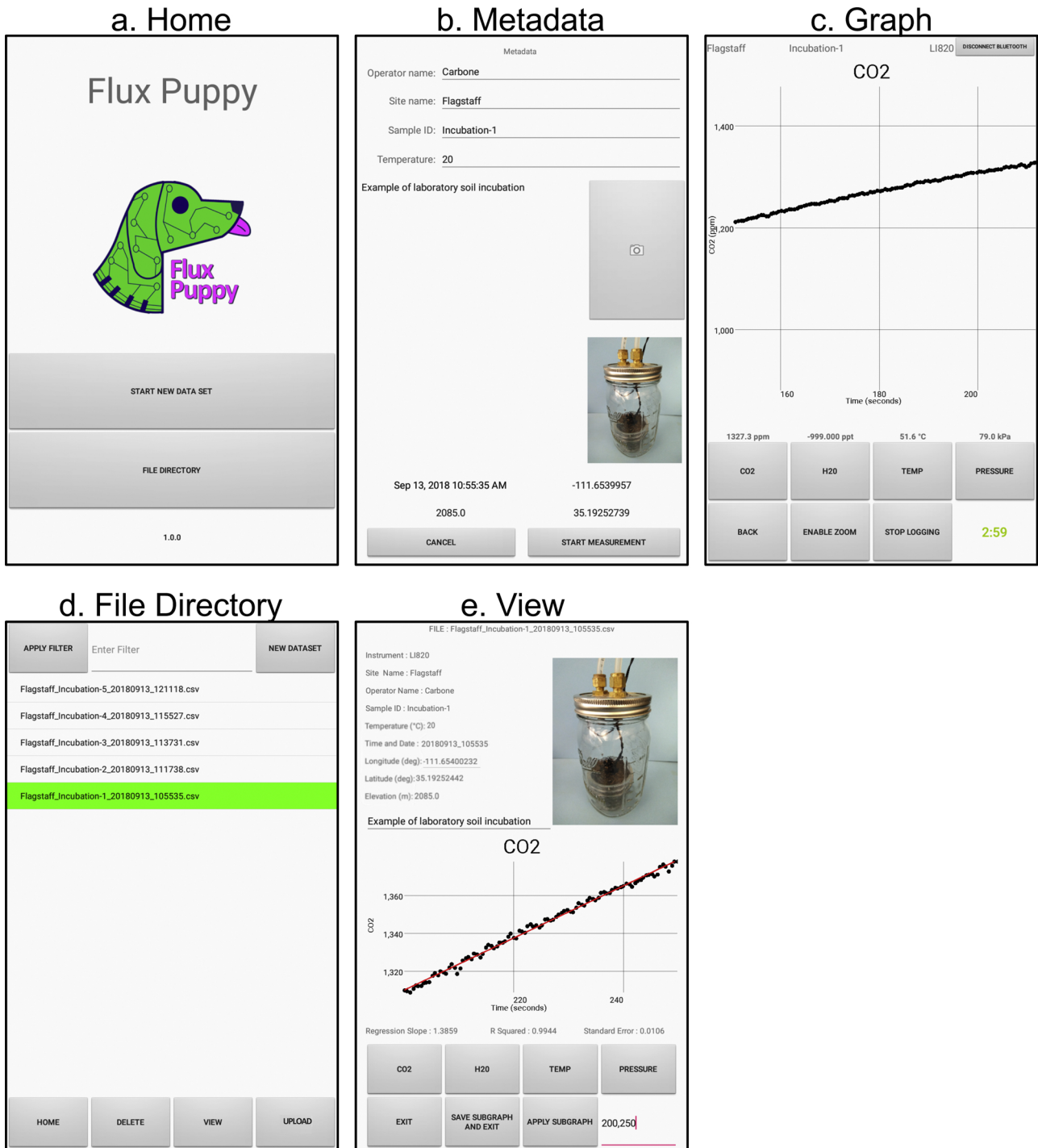

Fig. 3. The five screens in Flux Puppy: a) Home screen b) Metadata screen c) Graph screen d) File Directory screen e) View screen.

screen (Fig. 3c).

The Graph screen (Fig. 3c) is where communication with the IRGA occurs. Once on this screen, the user is prompted to select which connection to the IRGA they are using: Flux Puppy *Leashed* (connecting the Android device directly to the IRGA via a serial-to-USB cable) or *Unleashed* (wireless via Bluetooth). Once the connection mode has been selected, the app automatically detects the IRGA that is being used (LI-820, 830, 840, 850). After the analyzer is connected to the Android device, data will automatically stream into the app and appear on the live graph readout. There is a warning at the top of the screen that will remain until the IRGA has reached proper operating temperature for recording data. While on the Graph screen, the user can record a new

data set and zoom the X and Y axes of the graph through pinch-zoom gestures, all while maintaining the ability to switch between the different data streams being output by the IRGA. These data streams and their units are: CO<sub>2</sub> (ppm), H<sub>2</sub>O (ppt), cell temperature (°C), and cell pressure (kPa). The Graph screen relies on the Graph Manager object. This object parses the IRGA data and passes it to the appropriate graph (CO<sub>2</sub>, H<sub>2</sub>O, cell temperature, cell pressure) on the Graph screen, as well as saving it to the raw data file.

To begin collecting data, the user presses the “Start Logging” button and the graph resets to show only new data. A countdown timer (default is 5 min) is displayed on this screen and will begin once the logging has started. A dog barking sound will go off when the timer is

**Table 2**  
Metadata screen fields, autofill and requirements.

Metadata	Autofill	Required
Operator Name	Default last data entry	Yes
Site Name	Default last data entry	Yes
Sample ID	–	Yes
Temperature	–	No
Comments	–	No
Time	Always from tablet	No
Date	Always from tablet	No
Latitude	With GPS signal	No
Longitude	With GPS signal	No
Elevation	With GPS signal	No
Photo	–	No

elapsed to notify the user. To end collecting data, the user presses “Stop Logging” and they can press the “Save and Exit” button to proceed to the file directory, or they can begin recording a new data set, which will overwrite the previous one. After the “Save and Exit” button has been pressed, all the graph data will be saved to the device, along with its corresponding metadata file and photo file. This new dataset will subsequently be listed in the File Directory screen (Fig. 3d).

The File Directory screen (Fig. 3d) displays all of the Flux Puppy datasets currently saved in the app. Dataset files are sorted in chronological order, with the newest at the top. The data and meta-data files are saved in CSV format with a text header row. The naming convention is: Sitename\_sampleID\_date\_time.csv, where date is stored as YYYYMM-MDD and time as HHMMSS. To perform operations on datasets, the user must first select a dataset by pressing its name, highlighting it green. When an item is highlighted, three operations can be performed: deletion (“Delete” button), viewing (“View” button), and transfer out of the app (“Email” button). Additionally, the datasets displayed can be sorted using the Filter function, which is activated by typing a filter string in the “Enter Filter” text box, and then pressing the “Filter” button. One or more datasets can be highlighted before selecting “Delete”. The user will be prompted with a warning message asking them to confirm their choice. The “View” option can only be selected when a single dataset has been highlighted. Once “View” is selected, the user will be taken to the View screen (Fig. 3e) to view their selected dataset.

The File Directory screen (Fig. 3d) is also where data files can be transferred off the Android device via email (e.g. Gmail and Outlook) and shared drive clients (e.g. Google Drive and Dropbox). When one or more files are selected on the File Directory screen, the user may choose the “Upload” button. They will be prompted to select from a menu of transfer apps that are currently installed on the device. If the user’s

device does not have a transfer app currently installed, they will need to download one before this part of the app can be used. All highlighted datasets will be attached automatically. We recommend that users set up an email/shared drive account dedicated for this purpose, to keep data and work emails separate, and provide cloud back-up of all data.

The View screen (Fig. 3e) displays the CO<sub>2</sub> data, metadata, and photo that are within a dataset. This screen uses the Line Graph object and the Graph Manager object to reconstruct the data graphs and display them on screen. New metadata can be added in the comments section of this screen, for example if something occurred during the measurement that needs to be documented. This screen also allows the user to create a subset of the CO<sub>2</sub> data by prescribing, in the text entry box in the lower right corner of the screen, the x-axis values to trim the data file. The user can also calculate simple statistics on the data or subset of data. By pressing “Apply Subgraph” a linear regression model is fit through the selected subset of data. The regression slope, R-squared, and standard error for the regression slope following are then displayed on the screen. A new subset data and metadata file can be created with these new statistics and displayed as a new dataset on the File Directory screen; in this way, the original dataset is never lost.

### 3. Example

We used Flux Puppy to conduct a simple laboratory soil incubation experiment to demonstrate the format and content of the data files, and the ease with which measurements and analysis can be conducted. For this, we placed soil in a mason jar fitted with gas inlet and outlet ports on the lid of the jar. A temperature probe was placed within the soil. We used Flux Puppy to make five sequential five-minute measurements over the next two hours as the soil was warmed in a water bath from 20 °C to 40 °C. We used the “Apply Subgraph” option on the View screen to trim any extraneous or noisy CO<sub>2</sub> values at the start and end of each measurement period, and visually assessed the quality of our measurements using the in-app graphing features. We used the soil temperature manually entered on the Metadata screen and the regression slopes reported on the View screen (both of which are exported in the Metadata text file) to calculate CO<sub>2</sub> fluxes and establish a simple temperature-respiration relationship. An example of a raw data file, photo file, and concatenated metadata files summarizing the five sequential five-minute measurements are shown in Fig. 4a–c. Data derived from Fig. 4b are plotted in Fig. 4d, using the temperature and in-app calculated regression slopes. The CO<sub>2</sub> fluxes were calculated using the regression slope and jar volume, and were normalized against dry soil mass and scaled up to a daily value. This analysis shows how output from the app can quickly be used for analysis and visualization, without

**a. Sample data file**

Runtime	Year	Month	Day	Hour	Minute	Second	CO2	H2O	Temperature	Pressure
0	2018	8	13	11	4	0	1029	-999	51.6	78.99
1	2018	8	13	11	4	1	1030	-999	51.6	78.99
2	2018	8	13	11	4	2	1032	-999	51.6	78.99
3	2018	8	13	11	4	3	1035	-999	51.6	78.99
4	2018	8	13	11	4	4	1038	-999	51.6	78.99
5	2018	8	13	11	4	5	1038	-999	51.6	78.99
6	2018	8	13	11	4	6	1040	-999	51.6	78.99
7	2018	8	13	11	4	7	1042	-999	51.6	78.99
8	2018	8	13	11	4	8	1043	-999	51.6	78.99
9	2018	8	13	11	4	9	1047	-999	51.6	78.99
10	2018	8	13	11	4	10	1048	-999	51.6	78.99

**b. Combined metadata files from all five incubations**

Instrument	Operator Name	Site Name	Sample ID	Temperature	Comments	Time and Date	Longitude	Latitude	Elevation	R Squared	Regression Slope	Standard Error	X Start Range	X End Range	AppVersion
LI820	Carbone	Flagstaff	Incubation-1	20	Example of	20180913_105535	-111.654	35.193	2085	0.9494	0.75	0.0138	100.0	250.0	1.0.0
LI820	Carbone	Flagstaff	Incubation-2	25	Example of	20180913_111738	-111.654	35.193	2085	0.9894	0.80	0.0034	100.0	250.0	1.0.0
LI820	Carbone	Flagstaff	Incubation-3	30	Example of	20180913_113731	-111.654	35.192	2085	0.9938	0.85	0.0028	100.0	250.0	1.0.0
LI820	Carbone	Flagstaff	Incubation-4	35	Example of	20180913_115527	-111.654	35.192	2085	0.995	0.95	0.0023	100.0	250.0	1.0.0
LI820	Carbone	Flagstaff	Incubation-5	40	Example of	20180913_121118	-111.654	35.192	2085	0.9962	1.11	0.0025	100.0	250.0	1.0.0

**c. Sample photo file**



**d. Plot of temperature-CO<sub>2</sub> flux relationship**

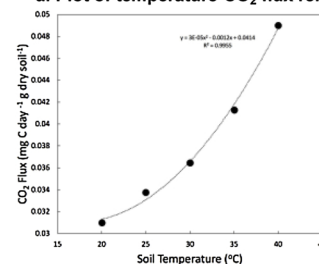

**Fig. 4.** Laboratory incubation experiment results. a) first ten lines from a sample data file b) sample metadata files combined from all five incubations c) sample photo from metadata and d) a plot of the temperature-CO<sub>2</sub> flux relationship. Because of the high R-squared values the regression standard errors are too small to be visible when plotted.

having to externally trim the raw data files, calculate regression slopes, or to transcribe metadata from a field notebook in Excel, Matlab, or R.

#### 4. Discussion

Flux Puppy has multiple advantages over other currently available options. Foremost, it is an open-source app that can be customized to the user's needs. We note that making minor modifications does require some knowledge of computer programming, but does not require training as a computer scientist or software engineer. Flux Puppy runs on a handheld Android tablet or phone, allowing for a measurement system to be lower in cost, more convenient and portable, and have longer battery life than with a Windows laptop computer. Flux Puppy bundles the typical "field notebook" metadata with the actual data collection, and expands the metadata to include photos and GPS. Flux Puppy allows for basic data processing and statistical calculations, which provide instantaneous quality control at the time of measurement. Wireless transfer of data out of the app is facilitated by integrating third-party email and cloud storage tools. All of these features save large amounts of time for the user by making the data collection process more convenient and more efficient.

Our goal with the first version of Flux Puppy was to make a very simple and customizable software base for portable manual measurements of CO<sub>2</sub> and H<sub>2</sub>O fluxes. However, there are numerous future additions that could improve the software for many users. For example, a radio frequency identification (RFID) or barcode scanner could be incorporated to automate metadata entry for frequently visited measurement locations. Data from additional sensors such as temperature, moisture, or humidity could be read by a microprocessor in-line with the serial output of the IRGA, and then passed on to the Flux Puppy app (software for this is already in development at <https://github.com/dabasler/fluxdatalink>). The current version of our software uses a linear fit for regression slope calculation. This could be expanded to include polynomial or other nonlinear functions. Or the software could be used to make syringe-injection concentration measurements of CO<sub>2</sub>, with an integration calculation mode. There are endless additional statistics packages that could be implemented for individual users and applications. The 800-series LI-COR IRGAs are light enough to be flown on a large unmanned aerial vehicle, and class II Bluetooth devices have a range of 100 m so the IRGA and Android device could be physically separated, with data sent wirelessly from an airborne IRGA to a device on the ground. This would permit measurements of CO<sub>2</sub>/H<sub>2</sub>O profiles within and above tall vegetation without the need for tower infrastructure.

#### 5. Conclusions

We developed an enhanced data-logging app to interface with the LI-800 series IRGAs that is easier to use than the existing LI-COR Windows-based software interface. Our app is publicly available, open-

source, and can be customizable to the user's needs. Our app allows for metadata entry, real time data visualization, basic data processing, and wireless transfer out of the app for the data set collected. Our app runs on a handheld device, that can operate wirelessly, avoiding the need for connection cords and a laptop in the field. This increases portability and battery lifetime of a measurement system. Together with the IRGA, small pump, and battery, the entire system fits inside a relatively small case, weighing less than 6 kg, and costing less than \$6000 US dollars.

For the above reasons, the whole system we have described will be of interest to many in our community who want to conduct chamber-based measurements of CO<sub>2</sub> fluxes, including leaf, stem, and soil respiration in the field, and incubations of soil or plants in the laboratory. Conceivably, it could also be used with clear chambers to make measurements of net photosynthesis at leaf-level or net ecosystem exchange at the mesocosm scale. We encourage the community to take Flux Puppy for a walk, and contribute to development and improvement of the code.

#### Acknowledgements

This software was initially developed by undergraduate students SB, JB, AG, and JK through the School of Informatics, Computing and Cyber Systems (SICCS) Computer Science (CS) Senior Capstone course at Northern Arizona University. ADR and MSC conceived of the project and advised the Capstone students in development of the software. We thank Anna Paula Chaves and Eck Doerry for their leadership of this course. BS and DB modified and finalized the version of Flux Puppy presented here. ADR, MSC, JML, and TTR designed and built the flux system. All authors, as well as Harvard Forest REU students Brooklynn Davis, Kyle Wyche and Emory Ellis, tested the system and app extensively in the lab or field. MSC conducted the laboratory incubation. MSC and ADR wrote the paper with input and approval from all authors. ADR acknowledges funding from the National Science Foundation (DEB-1741585, DEB-1237491). DB acknowledges funding from the Swiss National Science foundation (PSBSP3-168701). Sandra Boynton's Snuggle Puppy provided inspiration.

#### References

- Arnone, J.A., Obrist, D., 2003. A large daylight geodesic dome for quantification of whole-ecosystem CO<sub>2</sub> and water vapour fluxes in arid shrublands. *J. Arid Environ.* 55 (02), 629–643. [https://doi.org/10.1016/S0140-1963\(02\)00291-4](https://doi.org/10.1016/S0140-1963(02)00291-4).
- Lavigne, M.B., Ryan, M.G., Anderson, D.E., Baldocchi, D.D., Crill, P.M., Fitzjarrald, D.R., Striegl, R.G., 1997. Comparing nocturnal eddy covariance measurements to estimates of ecosystem respiration made by scaling chamber measurements at six coniferous boreal sites. *J. Geophys. Res. Atmos.* 102 (D24), 28977–28985. <https://doi.org/10.1029/97JD01173>.
- Livingston, G.P., Hutchinson, G.L., 1995. Enclosure-based measurement of trace gas exchange: applications and sources of error. *Biogenic Trace Gases: Measuring Emissions From Soil and Water*. Blackwell Scientific Publications, Oxford, pp. 14–51.
- Seyednasrollah, B., Basler, D., Beals, S., Beasley, J., Greene, A., Kelroy, J., Carbone, M.S., Richardson, A.D., 2018. FluxPuppy: Android Interface to Licor LI-820 and LI-840 gas analyzers (Version v1.0.0). Zenodo. <https://doi.org/10.5281/zenodo.1413689>.